

3500/4 Art. 1757

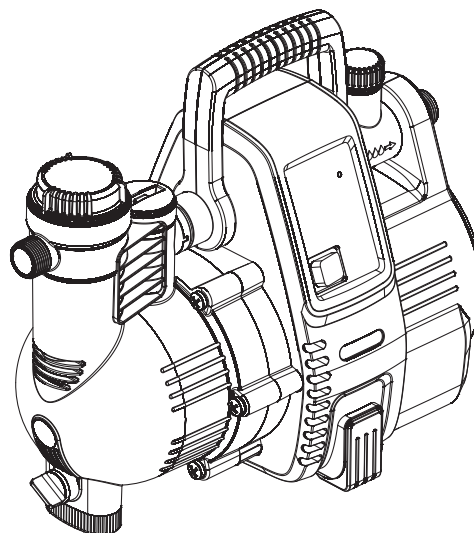

4000/5 Art. 1758

en Operator's manual
Automatic Home & Garden Pump

1. SAFETY INSTRUCTIONS 2
 2. INSTALLATION 3
 3. OPERATION 3
 4. MAINTENANCE 4
 5. STORAGE 4
 6. TROUBLESHOOTING 4
 7. TECHNICAL DATA 5
 8. ACCESSORIES 5
 9. WARRANTY/SERVICE 6

Translation of the original instructions.



This appliance is not intended for use by persons (including children) with reduced physical, sensory or mental capabilities, or lack of experience and knowledge, unless they have been given supervision or instruction concerning use of the appliance by a person responsible for their safety. Children should be supervised to ensure that they do not play with the appliance. (IEC 60335-1)

This appliance can be used by children aged from 8 years and above and persons with reduced physical, sensory or mental capabilities or lack of experience and knowledge if they have been given supervision or instruction concerning use of the appliance in a safe way and understand the hazards involved. Children shall not play with the appliance. Cleaning and user maintenance shall not be made by children without supervision. (EN 60335-1)

Intended use:

The **GARDENA Automatic Home & Garden Pump** is intended for private use in the home and hobby garden and is not intended to be used for operating irrigation equipment and systems in public gardens. It can be used for pumping rainwater, tap water and chlorinated water.

The product is not intended for continuous operation (e.g. industrial applications, continuous circulating operation).



DANGER!

→ **Corrosive, easily combustible, aggressive or explosive liquids (such as gasoline, petroleum or nitrothinner), saltwater and food intended for consumption must not be pumped.**

Pressure amplification:

If you use the pump for pressure amplification, the maximum permissible internal pressure must not exceed 6 bar. Consequently, the maximum inlet pressure is:

- Model 1757 3500/4 – 2.0 bar
- Model 1758 4000/5 – 1.5 bar

To ensure the correct inlet pressure, it is essential to use an adjustable pressure limiting valve.

1. SAFETY INSTRUCTIONS

IMPORTANT!

Read the operator's manual carefully before use and keep for future reference.

Symbols on the product:



Read operator's manual.

General safety warnings

Electrical safety



DANGER! Electric shock!

Risk of injury due to electric current.

→ **The product must be supplied through a residual current device (RCD) having a rated residual operating current not exceeding 30 mA.**



DANGER! Electric shock!

Risk of injury due to electric current.

→ **Disconnect the product from the mains before you maintain or replace parts. Thereby the disconnected socket must be in the visual range.**

Safe operating practices

The water temperature should not exceed 35 °C.

The pump must not be used when people are in the water.

Leaking lubricants can contaminate the pumped liquid.

Circuit breakers

Dry-running protection: If no water is pumped (undercurrent) the pump switches off automatically.

Anti-lock protection: If the motor blocks (overcurrent), the pump switches off automatically.

Additional safety warnings

Electrical safety



DANGER! Cardiac arrest!

This product makes an electromagnetic field while it operates. This field may under some conditions interfere with active or passive medical implants. To decrease the risk of conditions that can possibly injure or kill, we recommend persons with medical implants to speak with their physician and the medical implant manufacturer before you operate the product.



DANGER! Electric shock!

The product must not be operated if there are people in the swimming pool or garden pond.

→ **Make sure that the electrical plug and socket connections are fitted in an area which cannot be flooded.**

→ **Protect the power plug from moisture.**

Connecting cable



DANGER! Electric shock!

With a cut off mains plug, moisture can get into electrical parts via the mains cable and cause a short circuit.

→ **Do not cut the mains plug off (e. g. to feed through a wall).**

If the supply cord is damaged, it must be replaced by the manufacturer, its service agent or similarly qualified persons in order to avoid a hazard.

According to DIN VDE (German Electrical Engineers' Association) 0620, mains power cables and extension cables must not have a smaller cross-section than the rubber-sheathed cables of the designation H07RN-F.

The cable length must be at least 10 m.

Data indicated on the type plate must match technical data of the mains supply.

Disconnect the product from the mains when it is not in use.

Protect plug and power cable from heat, oil and sharp edges.

Do not use the power cable to carry or to unplug the pump.

As an additional safety device an approved safety switch can be used.

→ Please ask your electrician for his advice.

Only use extension cables with earth connectors for operating this pump.

A damaged pump must not be used.

Before operating the pump look and see if there is any damage to the pump (especially to the power cable and plug).

→ In case of damage, please have the pump checked by our GARDENA Service Centre.

Personal safety



DANGER! Risk of suffocation!

Small parts can be easily swallowed. There is also a risk that the poly-bag can suffocate toddlers. Keep toddlers away when you assemble the product.



DANGER! Risk of injury due to hot water!

If the electronic control is defective or if the water supply on the intake side of the pump fails, any water remaining in the pump may heat up, generating a risk of injuries caused by hot water on leakage.

→ **Disconnect the pump from the mains, let the water cool (approx. 10 – 15 min.) and secure the water supply on the intake side before putting into operation again.**

Do not use the product while you are tired or under the influence of drugs, alcohol or medication. A moment of inattention while you operate the product may result in serious personal injury.

When connecting the pump to the water supply system, the country-specific sanitary regulations must be observed to prevent water not of drinking water quality being drawn back in.

When water flows through the pump it is no drinking water anymore.

When using the product, cover hair and do not wear scarves and other loose items of clothing.

Make sure that no children or unauthorised persons are within reach of the pump and the pumped medium without supervision.

In order to avoid dry-running of the pump, take care that the end of the suction hose is always submerged into the water.

→ Before each operation, fill the pump with liquid to be pumped (approx. 2 to 3 l).

The pump must be located on solid, even ground, protected from flooding. Take care that the pump cannot fall into water.

Very fine sand can pass through the integrated filter (mesh size 0.45 mm) and cause accelerated wear in the hydraulic parts.

→ For sandy water, you should additionally use the **GARDENA Pump Preliminary Filter, art. 1730** (mesh size 0.1 mm).

The temperature of the pumped liquid must be between 2 °C and 35 °C.

Only store the product in temperatures between 2 °C and 70 °C.

2. INSTALLATION



DANGER! Electric shock!

Risk of injury due to electric current.

→ **Disconnect the product from the mains before you install the product.**

Installation location [Fig. I1]:

The pump must be installed in a location with sufficient ventilation in the area of the ventilation slots. It must be at a distance of at least 5 cm from the walls. No dirt contamination (e.g. sand or soil) may be sucked in through the ventilation slots.

Set up the pump so that it is prevented from slipping and that an appropriately large collecting vessel for draining the pump or the system can be placed under the drain screw ①.

Install the pump at a safe distance (min. 2 m) from the pumping medium.

If possible, install the pump higher than the surface of the water to be pumped. If this is not possible, install a vacuum-resistant shut-off device between the pump and the suction hose to allow the integrated filter to be cleaned.

If the system is permanently installed, appropriate shut-off devices must be installed on the input and output sides. Important for maintenance and cleaning work on the pump or for shutdown, for example.

Connections:



CAUTION!

The GARDENA connection pieces on the intake and delivery sides may only be tightened by hand. Check whether the seal ring is present and undamaged before screwing the suction hose onto the suction inlet. When using metal connections, damage could occur on the connection thread due to inappropriate assembly. Therefore, screw on the connection fittings with the utmost care. Use sealing tape only for sealing metallic connection fittings.

Suction side:

Do not use modular water hose components on the suction side! A vacuum-tight suction hose must be used e.g.:

– **GARDENA Suction Hose Art. 9090/9091**

– **GARDENA Bore Hole Suction Hose Art. 1729**

– **GARDENA Suction Hose sold by the metre with GARDENA Hose Clamp Art. 7192/7191.**

If very fine dirt is present, we recommend the use of a **GARDENA Pump preliminary filter Art. 1730/1731** in addition to the integrated filter.

To reduce the pump repriming time, we recommend to use a suction hose with backflow preventer, which prevents the suction hose emptying automatically when the Automatic Home & Garden Pump is switched off.

Important for fixed installation:

For greater suction heads, use a suction hose with a small diameter (3/4").

Pressure side:

A pressure-resistant hose must be used on the pressure side, e.g.:

– **GARDENA Garden Hose (3/4") Art. 18113 with GARDENA Connection Set Art. 1752.**

Important for fixed installation:

If the product is permanently installed in an enclosed space, only flexible hoses (e.g. reinforced hoses) may be used for connecting the service water supply, rather than rigid piping. Flexible hoses will reduce the noise level and prevent damage caused by pressure surges. Install fixed pipes at an upward gradient on the first 2 m only. To avoid damage to the thread, ensure careful and accurate installation when using metal connections.

To connect the suction hose [Fig. I2]:

1. Screw the suction hose fitting ③ onto the suction inlet ④ and tighten it by hand.
2. Slide the suction hose ② onto the suction hose fitting ③ and secure it e.g. with a **GARDENA Hose Clamp Art. 7192/7191**.
3. For suction head exceeding 4 m secure the suction hose (e.g. by fastening it to a wooden post).
The pump and the suction hose are relieved from the weight of the water.

To connect the pressure hose [Fig. I3]:

The pressure hose can be connected either to the delivery side 33.3 mm (G1)-thread of the 120° swivelling connection ⑤ and/or of the horizontal connection ⑧.

1. Screw the tap connector ⑦ onto the pressure outlet ⑤/⑧ and tighten it by hand.
2. Connect the pressure hose with hose connector ⑥ onto the tap connector ⑦.

3. OPERATION



DANGER! Electric shock!

Risk of injury due to electric current.

→ **Disconnect the product from the mains before you fill the pump.**

To start the Automatic Home & Garden Pump [Fig. O1/O2]:

NOTE: The specified maximum self-priming level (see 7. TECHNICAL DATA) is reached only when the pump is full and the pressure hose is held up high directly upstream of the pressure output during the first self-priming phase. This ensures that the pumped medium cannot leak from the pressure hose. When using a full suction hose with a check valve, it is not necessary to hold up the pressure hose.

1. Unscrew the lid ⑨ of the filter chamber with the spanner ① provided.
2. Slowly fill in the liquid to be pumped via the filler connection ⑩ up to the overflow (approx. 2 to 3 l) until the water level no longer drops under the suction side inlet or the water flows out at the horizontal connector.
3. **With fixed installation:** Unscrew the cover ⑭ and fill with liquid until it flows towards the horizontal connector.
4. Empty any water remaining in the delivery hose so that the air can escape during filling and priming.
5. Open any shut-off devices in the delivery line (watering accessories, tap, etc.) so that air can escape before the priming procedure begins.
6. **With fixed installation:** If the delivery line cannot be emptied due to fixed installation, unscrew the cover ⑭. Considerable amounts of liquid may escape. Please keep a sufficiently large receptacle at hand for collection.
7. Tighten the lid ⑨ of the filter chamber up to the stopper ④.
8. **Without fixed installation:** Lift up the delivery hose just behind the pressure outlet.
9. Plug the power plug of the connecting cable into a mains socket.
10. Push the on/off switch ⑪ to position I.
The on/off switch lights up and the pump starts.

The suction process can take up to 6 min. If no water is pumped afterwards, the pump will shut down automatically and display Error 2 (see 6. TROUBLESHOOTING).

11. Close shut-off devices in the delivery pipeline again when the pump begins to deliver water continuously.

The pump turns off automatically approx. 10 seconds after closing the shut-off device.

The pump is ready for operation (Standby).

Electronic control:

The pump features an electronic controller.

If the pressure level falls below the start-up pressure, the pump is started automatically.

As soon as the water supply is no longer required, the pump is switched off automatically.

Low quantity programme and leakage warning:

Leakage warning:

In the event of a leakage or a dripping tap, the pressure constantly falls below the turn-on pressure and the pump switches itself on and off continuously.

If the pump is constantly switched on and off, the pump switches off automatically to prevent unwanted water leakage (error 4 "Leakage warning" is displayed).

Low quantity programme:

To prevent the pump from switching off earlier when used with low quantity of water (e.g. washing machines or drip irrigation), the leakage warning is only activated after 60 minutes.

Switching the pump on and off cyclically during the small quantity program has no effect on the service life of the pump.

Use of washing machines:

Upon completion of the low quantity water supply cycle in washing machines, the 60-minute operating interval of the low quantity programme is automatically reset to normal operation of the pump and allows a trouble-free use of the washing machine for > 60 minutes.

For continuous drip irrigation:

If the low quantity programme is to be used for more than 60 minutes, the irrigation must be disrupted for at least 5 minutes before the end of the 60 minute period. The low quantity programme can then be used for a further 60 minutes.

4. MAINTENANCE



DANGER! Electric shock!

Risk of injury due to electric current.

→ Disconnect the product from the mains before you maintain the product.

To clean the filter [Fig. M1/M2]:

1. If applicable, close all the shutoff devices on the intake side.
2. Loosen the lid ⑨ of the filter chamber with the spanner ① provided.
3. Remove the filter unit ⑫/⑬ vertically upwards.
4. Hold the cup ⑭ firmly, turn the filter ⑮ counterclockwise **1** and remove the filter **2** (bayonet fitting).
5. Clean the cup ⑭ under running water and clean the filter ⑮ e.g. with a soft brush.
6. Assemble the filter again in reverse order.
7. Start the pump (see 3. OPERATION).

To clean the check valve [Fig. M3/M4]:



CAUTION!

The pump must not be operated without the check valve.

1. If applicable, close all the shut-off devices on the intake side.
2. Open all tapping points so that the pressure escapes on the pressure side. Now close the tapping points again so that the connected pipes do not drain via the pump.

3. Loosen the cover ⑭ of the check valve with a suitable tool.
4. Remove the check valve ⑮ and clean it under running water.
5. Assemble the check valve ⑮ again in reverse order.
6. Start the pump (see 3. OPERATION).

5. STORAGE

To put into storage [Fig. S1]:

The product must be stored away from children.

1. Push the on/off switch ⑩ to position **0**.
2. Disconnect the pump from the mains.
3. Open the consumer on the pressure side.
4. Remove the connected hoses on the pressure and suction side.
5. Unscrew drain bolt ①.
6. Tilt the pump to the suction and pressure side until water is no longer discharged from either side.
7. Store the pump in a dry, enclosed and frost-free place.

Disposal of the product:

(in accordance with RL2012/19/EC)



The product must not be disposed of to normal household waste. It must be disposed of in line with local environmental regulations.

IMPORTANT!

→ Dispose of the product through or via your municipal recycling collection centre.

6. TROUBLESHOOTING



DANGER! Electric shock!

Risk of injury due to electric current.

→ Disconnect the product from the mains before you troubleshoot the product.

To troubleshoot with the error diagnosis system [Fig. T1]:

The pump is equipped with an error diagnosis system which indicates various error states via the error LED ⑥.

1. Disconnect the pump from the mains.
2. Make the respective remedies from the table below.
3. Start the pump again.
The error display has been cleared and the pump is ready for operation again.

Problem	Possible Cause	Remedy
Error-LED flashes 1 time (with a 2 second break)	The pump does not pump water for 30 seconds during the initial operation.	
Pump does not suck water	Pump was not sufficiently filled with liquid to be pumped.	→ Fill the pump and make sure that water does not drain out on the pressure side during the suctioning process (see 3. OPERATION).
	Air cannot escape on the pressure side, because the pressure side outlets are closed.	→ Open the pressure side outlets (see 3. OPERATION).
Pump does not start	The pump housing has heated up and the thermal circuit breaker has been activated.	1. Open possible shut-off device in the pressure line (release pressure). 2. Ensure sufficient ventilation and let the pump cool down for 20 min.
	The impeller is blocked.	1. Loosen the impeller (see "To loosen the impeller"). 2. Let the pump cool down for 20 min.
Only for Art. 1758: Flow sensor signal is faulty	The flow sensor is dirty.	→ Clean the flow sensor (see "To clean the flow sensor").

Problem	Possible Cause	Remedy
Error-LED flashes 2 times (with a 2 second break)	<i>The pump does not pump water for 6 minutes during the initial operation.</i>	
Pump does not suck water	Problem on the suction side.	<ul style="list-style-type: none"> → Immerse the suction hose end under water. → Eliminate any leak on the suction side. → Clean the check valve on the suction line and check the installation direction. → Clean the suction filter on the suction hose end. → Clean the filter lid seal and turn the lid until the stopper (see 4. MAINTENANCE), → Clean the filter in the pump.
	Suction hose deformed or bent.	→ Use a new suction hose.
Pump does not start	The thermal circuit breaker has been activated (motor overheated).	→ Let the pump cool down for 20 min.
Error-LED flashes 3 times (with a 2 second break)	<i>The pump does not pump water for 30 seconds during the current operation.</i>	
Water supply disrupted on the suction side	Problem on the suction side.	<ul style="list-style-type: none"> → Immerse the suction hose end under water. → Eliminate any leak on the suction side. → Clean the check valve on the suction line and check the installation direction. → Clean the suction filter on the suction hose end. → Clean the filter lid seal and turn the lid until the stopper (see 4. MAINTENANCE), → Clean the filter in the pump.
	Suction hose deformed or bent.	→ Use a new suction hose.
Pump does not start	The thermal circuit breaker has been activated (motor overheated).	→ Let the pump cool down for 20 min.
Only for Art. 1758: Flow sensor signal is faulty	The flow sensor is dirty.	→ Clean the flow sensor (see "To clean the flow sensor").
Error-LED flashes 4 times (with a 2 second break)	<i>The pump switches off during on-going operation after 60 minutes.</i>	
Leakage warning is activated	Leak on pressure side (e.g. dripping tap).	→ Eliminate any leak on the pressure side.
	The maximum duration of the leakage warning (low quantity program 60 min. or 2 min.) has been exceeded.	<ul style="list-style-type: none"> → When using the low quantity programme, shorten the watering duration or interrupt for 5 minutes. → Increase the water consumption.
	The check valve is blocked.	→ Clean the check valve (see "To clean the check valve").
Only for Art. 1758: Flow sensor signal is faulty	The flow sensor is dirty.	→ Clean the flow sensor (see "To clean the flow sensor").
Error-LED is off	<i>Pump does not start or stops suddenly during operation</i>	
	Mains plug is disconnected.	→ Connect the mains plug.
	Power failure.	→ Check the fuse and the cables.
	RCD has triggered (residual current).	→ Disconnect the pump and contact the GARDENA Service.
	Electrical interruption.	→ Disconnect the pump and contact the GARDENA Service.
Error-LED is off	<i>Pump frequently switches on and off without water retrieval.</i>	
Only for Art. 1757 (see fig. T4)	Longer periods of non-use.	→ Pull piston (K) at the check valve several times prior to commissioning after longer periods of non-use.

To loosen the impeller [Fig. T2]:

If the impeller is stuck due to dirt, the **Error LED flashes 1 time (with a 2 second break)**.

1. Turn the motor shaft (16) with a screw driver.
This will loosen the blocked impeller.
2. Start the pump (see 3. OPERATION).

Only for Art. 1758: To clean the flow sensor [Fig. T3]:

If the flow sensor is stuck due to dirt, the **Error LED flashes (with a 2 second break)**.

1. Loosen both screws (17).
2. Remove the cover (18).
3. Loosen the screw (19) and remove the clip (20).
4. Loosen the cap (21) counterclockwise (e.g. with a screwdriver).
5. Remove and clean the impeller (22).
6. Clean the housing of the flow sensor.
7. Assemble the impeller (22) again in reverse order.
8. First insert the cover (18) at the top and then tighten both screws (17) at the bottom.
9. Start the pump (see 3. OPERATION).



NOTE: For any other malfunctions please contact the GARDENA service department. Repairs must only be done by GARDENA service departments or specialist dealers approved by GARDENA.

7. TECHNICAL DATA

Automatic Home & Garden Pump	Unit	Value (Art. 1757)	Value (Art. 1758)
Mains voltage	V (AC)	220 – 240	220 – 240
Mains frequency	Hz	50	50
Rated Power/ Standby consumption	W	800 / 1.5	1100 / 1.5
Connection cable	m	1.5 (H07RN-F)	1.5 (H07RN-F)
Max. delivery capacity	l/h	3500	4000
Max. pressure	bar	4.0	4.5
Max. delivery head	m	40	45
Max. suction height	m	7	8
Cut-in pressure	bar	1.9 ± 0.2	1.9 ± 0.2
Permitted internal pressure (delivery side)	bar	6	6
Weight	kg	8.1	12.5
Sound power level $L_{WA}^{1)}$: measured/guaranteed Uncertainty $k_{WA}^{1)}$	dB (A)	77 / 81 4	83 / 83 1

Measuring process complying with: ¹⁾ RL 2000/14/EC

8. ACCESSORIES

GARDENA Suction Hoses	Kink and vacuum-resistant, sold by the metre with 19 mm (3/4"), 25 mm (1") or 32 mm (5/4") diameter without fittings or in fixed lengths complete with fittings, suction filter and backflow preventer.	
GARDENA Suction Hose Fittings	For vacuum-resistant connection of the pump to the suction hose sold by the metre.	Art. 1723/1724
GARDENA Suction Filter with Backflow Preventer	To equip suction hoses with Backflow Preventer sold by the metre.	Art. 9093
GARDENA Bore Hole Suction Hose	For vacuum-resistant connection of the pump to boreholes or pipe networks. Length 0.5 m. With 33.3 mm (G1) female thread at both ends.	Art. 1729
GARDENA Pump Preliminary Filter	Recommended for pumping sandy water.	Art. 1730/1731
GARDENA Pump Connection Set	Connection Set for 1/2" Pressure Hoses.	Art. 1750
GARDENA Pump Connection Set	Connection Set for 3/4" Pressure Hoses.	Art. 1752

9. SERVICE/WARRANTY

9.1 Service:

Please find the current contact information of our service on the back page and online:

- Australia: <https://www.gardena.com/au/support/advice/contact/>
- New Zealand: <https://www.gardena.com/nz/support/advice/contact/>

9.2 Warranty:

Husqvarna provides a manufacturer's warranty against faulty workmanship in manufacture and/or defective components to initial purchaser for each new GARDENA branded product produced by Husqvarna and purchased in Australia. To make a valid claim under this manufacturer's warranty the product and proof of purchase must be provided to the retailer. This warranty does not cover damage caused by misuse, neglect, adjustments and/or modifications by the consumer or normal wear and tear, the costs of shipping and handling, travel expense, lost time, or pickup and delivery.

Australia

Our goods come with guarantees that cannot be excluded under the Australian Consumer Law. You are entitled to a replacement or refund for major failure and for compensation for any other reasonably foreseeable loss or damage. You are also entitled to have the goods repaired or replaced if the goods fail to be of acceptable quality and the failure does not amount to a major failure.

Husqvarna Australia Pty Ltd
(ABN 45 115 475 619)
4 Pioneer Avenue
Tuggerah NSW 2259
Tel: 1300 804 213

New Zealand

This manufacturer's warranty is in addition to the rights and remedies provided by the New Zealand Consumer Guarantees Act.

Husqvarna New Zealand Ltd
(Company No. 111861)
51 Aintree Avenue
Airport Oaks, Manukau 2022
Tel: 09 920 2410

Performance characteristics

Classic 3500/4

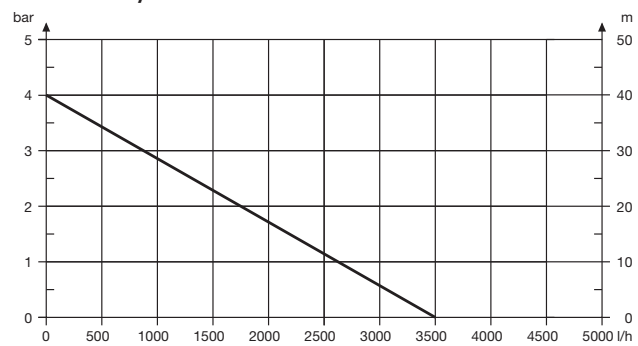

Comfort 4000/5

